

ICC-ES LISTED
ER-5110

ICC-ES LISTED
ER-9504

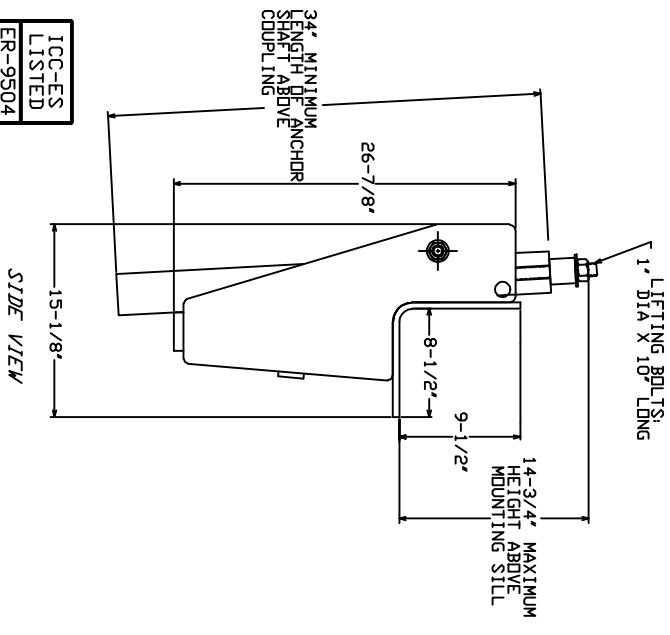

NOTES-

1. HOT DIP GALVANIZE PER ASTM A153-(LATEST REV.)
2. RECOMMENDED ANCHOR SHAFT CUTOFF LEVEL ABOVE THE BOTTOM OF THE FOOTING IS 11-1/4" FOR MAXIMUM LIFT DISTANCE.
3. FOR DETAILED INSTALLATION INSTRUCTIONS, READ CHANGE BULLETIN 01-0504.
4. MATERIAL SPECIFICATIONS:
BRACKET BODY : PER ASTM A36.
T-PIPE TUBE : MECHANICAL TUBING PER ASTM A512 OR A513.
LIFTING BOLTS : HEX HEAD BOLT PER SAE J429 GRADE 5.
CROSS BOLT : HEX HEAD BOLT PER SAE J429 GRADE 5.
5. SEE ICC-ES EVALUATION SERVICE INC., EVALUATION REPORT NO. ER-5110 FOR ALLOWABLE VALUES AND/OR CONDITIONS OF USE CONCERNING MATERIAL PRESENTED IN THIS DOCUMENT.
6. FOR A SS175 HELICAL PIER USE A C150-0474 T-PIPE.
FOR A SS200 HELICAL PIER USE A C150-0508 T-PIPE.
FOR A HS HELICAL PIER USE A C150-0475 T-PIPE.

CATALOG NUMBER
C150-0147

MECHANICAL RATINGS ON BRACKET:
WORKING LOAD: 60,000 LB.
ULTIMATE LOAD: 120,000 LB.

<p>CHANCE TOLERANCE CHART</p>		<p>HUBBELL POWER SYSTEMS</p>	
<p>CONFIDENTIAL: THIS DRAWING AND ITS CONTENTS ARE CONFIDENTIAL AND THE CONTENTS ARE NOT TO BE REPRODUCED, DISTRIBUTION OR SOLEMAY BE MADE WITHOUT THE WRITTEN CONSENT OF HUBBELL POWER SYSTEMS UNPUBLISHED ALL RIGHTS RESERVED UNDER THE COPYRIGHT LAWS.</p>			
<p>SIZE: SB</p>	<p>DMG NO: SA150-0147</p>	<p>CAT / PART / ASSY NO: C150-0147</p>	<p>REV: G</p>
<p>DO NOT SCALE THIS DRAWING</p>	<p>DRN BY: KSH</p>	<p>DATE: 6/7/05</p>	<p>SHEET 1 OF 1</p>